

D10P/L

Overhung load 3.5 lbs.,
.44" from output boss

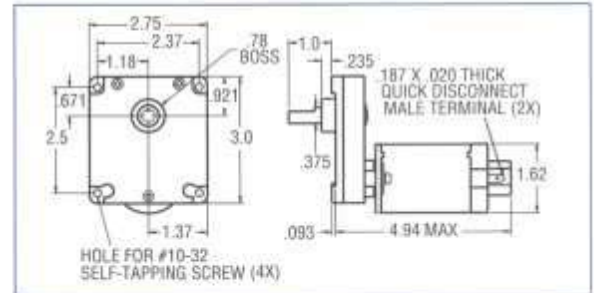
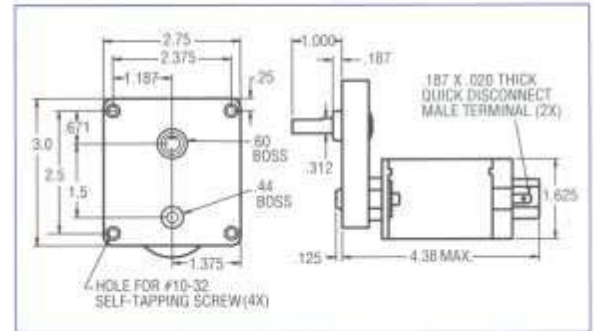

Input Motor	Gearmotor Characteristics	Nominal Gear Ratios						
		24	30	40	60	100	150	300
6000 RPM	F.L. Speed (RPM)	250	200	150	100	60	40	20
	Start Torque (in-lbs.)	2.2	2.8	3.6	5.5	9	14	28

Options • Available 12, 24 or 36 Volt • Replaceable Brushes • Hall Effect Encoder

D10H

Overhung load 7 lbs.,
.44" from output boss

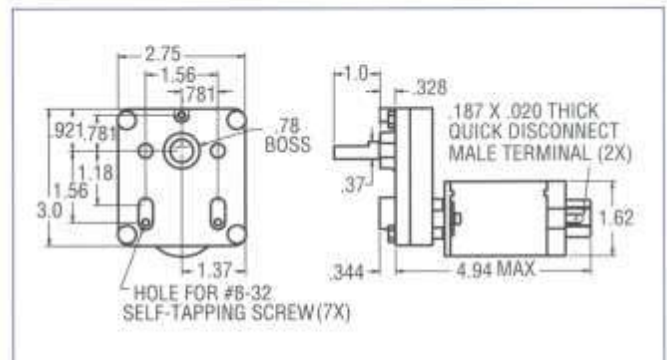

Input Motor	Gearmotor Characteristics	Nominal Gear Ratios									
		24	30	40	60	100	150	333	500	1000	1500
6000 RPM	F.L. Speed (RPM)	250	200	150	100	60	40	18	12	6	4
	F.L. Torque (in-lbs.)	2.2	2.8	3.6	5.5	9	14	30	52	75	75

Options • Available 12, 24 or 36 Volt • Replaceable Brushes • Hall Effect Encoder

D1H/L

Overhung load 7 lbs.
.44" from output boss

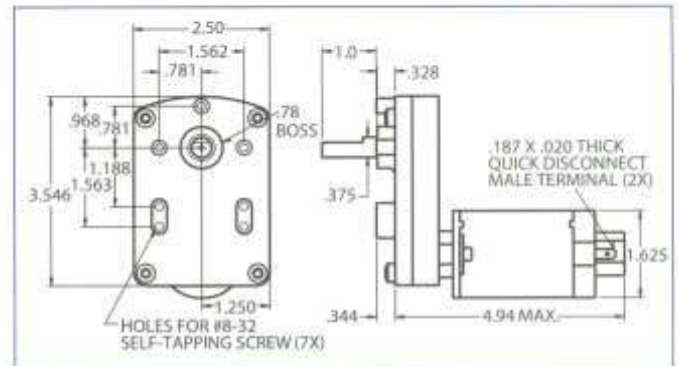

Input Motor	Gearmotor Characteristics	Nominal Gear Ratios									
		17	25	32	50	59	86	150	250	500	750
6000 RPM	F.L. Speed (RPM)	350	240	190	120	102	70	40	24	12	8
	F.L. Torque (in-lbs.)	1.6	2.2	4.2	5	6	8	14	23	75	75

Options • Available 12, 24 or 36 Volt • Replaceable Brushes • Hall Effect Encoder • Double Output Shaft

D1P

Overhung load 3.5 lbs.
.44" from output boss

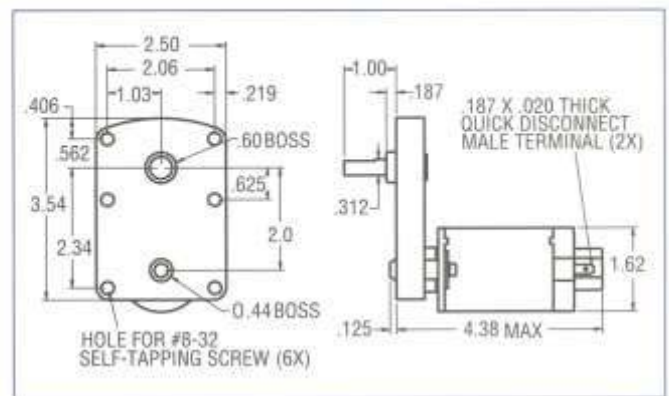

Input Motor	Gearmotor Characteristics	Nominal Gear Ratios									
		17	25	32	50	59	86	150	250	500	750
6000 RPM	F.L. Speed (RPM)	350	240	190	120	102	70	40	24	12	8
	F.L. Torque (in-lbs.)	1.6	2.2	4.2	5	6	8	14	23	45	45

Options • Available 12, 24 or 36 Volt • Replaceable Brushes • Hall Effect Encoder • Double Output Shaft

D3P/L

Overhung load 3.5 lbs.
.44" from output boss

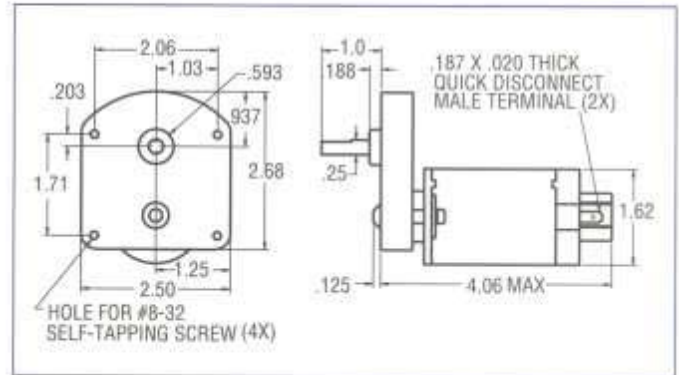

Input Motor	Gearmotor Characteristics	Nominal Gear Ratios							
		12	17	25	30	38	50	75	100
6000 RPM	F.L. Speed (RPM)	500	360	240	200	160	120	80	60
	F.L. Torque (in-lbs.)	1.2	1.6	2.2	2.8	3.5	5	7	9

Options • Available 12, 24 or 36 Volt • Replaceable Brushes • Hall Effect Encoder • Double Output Shaft

D3H

Overhung load 7 lbs.,
.44" from output boss

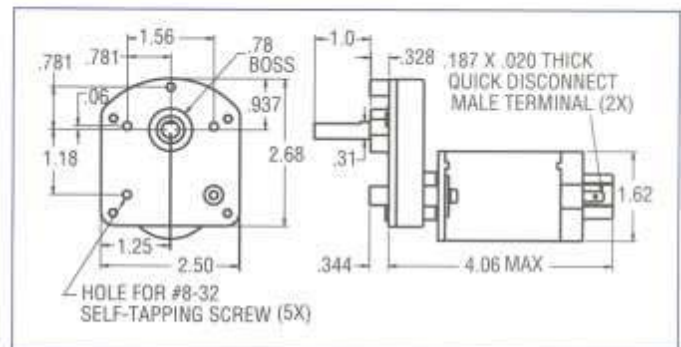

Input Motor	Gearmotor Characteristics	Nominal Gear Ratios							
		12	17	25	30	38	50	75	100
6000 RPM	F.L. Speed (RPM)	500	360	240	200	160	120	80	60
	F.L. Torque (in-lbs.)	1.2	1.6	2.2	2.8	3.5	5	7	9

Options • Available 12, 24 or 36 Volt • Replaceable Brushes • Hall Effect Encoder • Double Output Shaft

VW63

Overhung load 25 lbs.,
.50" from output boss

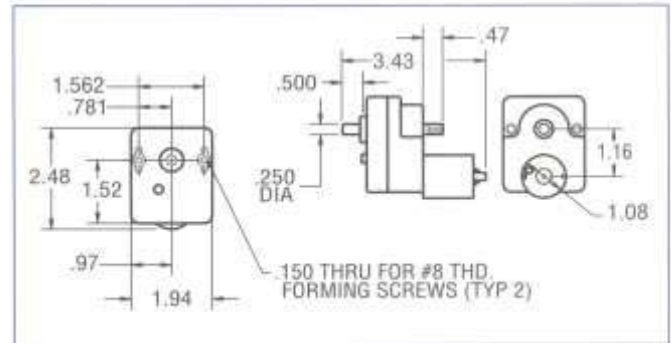

Input Motor	Gearmotor Characteristics	Nominal Gear Ratios						
		59	101	141	262	491	842	1273
2850 RPM	F.L. Speed (RPM)	49	28	20	11	6	4	3
	F.L. Torque (in-lbs.)	1.0	1.6	2.3	4.3	6.3	6.3	6.3

Options • Available 12 or 24 Volt • Internal Brushes • Double Output Shaft

VW15

Overhung load 50 lbs.,
.44" from output boss

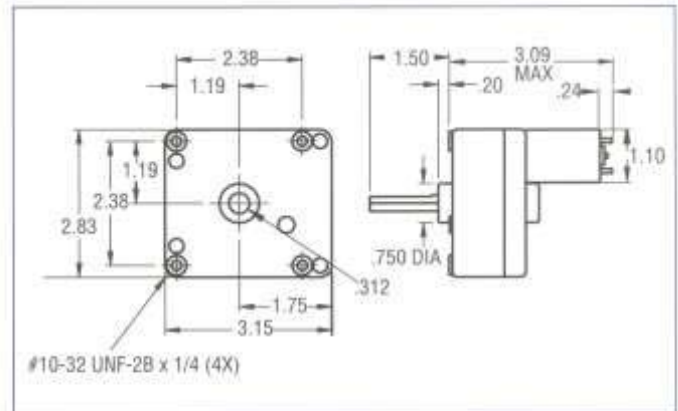

Input Motor	Gearmotor Characteristics	Standard Gear Ratios							
		33	50	100	155	260	515	1531	3085
2850 RPM	F.L. Speed (RPM)	87	57	29	18	11	5.6	2	1
	F.L. Torque (in-lbs.)	0.6	1	2	3	4	8	23	46

Options • Available 12 or 24 Volt • Internal Brushes • Double Output Shaft

VW16

Overhung load 50 lbs.,
.44" from output boss

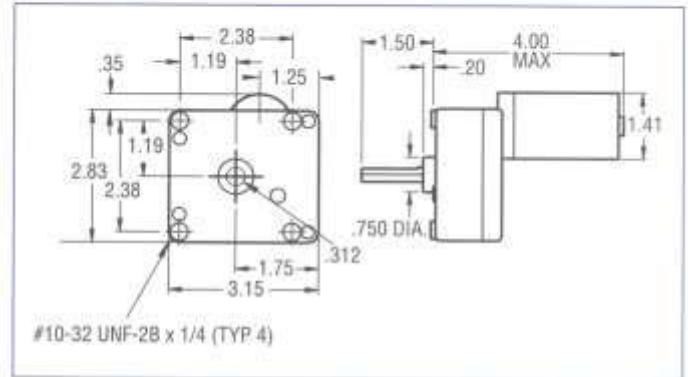

Input Motor	Gearmotor Characteristics	Standard Gear Ratios							
		19	31	76	103	169	329	1048	1811
3700 RPM	F.L. Speed (RPM)	195	119	49	36	22	11	3.5	2
	F.L. Torque (in-lbs.)	2	3	8	11	18	36	50	50

Options • Available 12 or 24 Volt • Internal Brushes • Double Output Shaft

D25

Overhung load 2 lbs.,
.25" from output boss

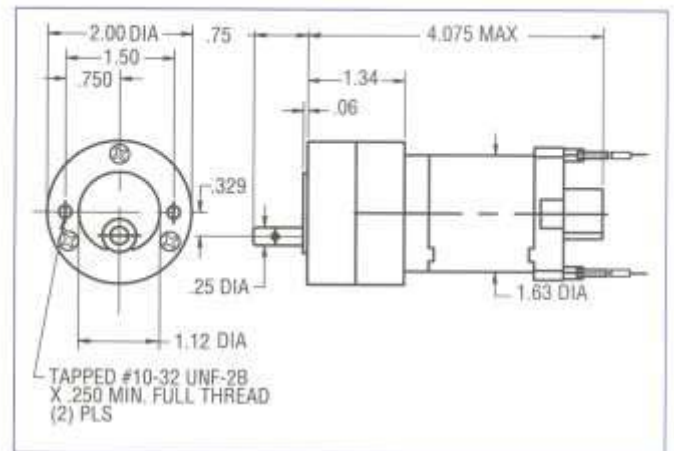

Input Motor	Gearmotor Characteristics	Standard Gear Ratios									
		8.3	15	33	79	133	300	533	1200	2133	5071
2900 RPM	F.L. Speed (RPM)	355	200	85	35	20	10	6	2.5	1.5	0.6
	F.L. Torque (oz.-in.)	4.5	8	18	43	63	90	90	90	90	40

Options • Available 12, 24 or 36 Volt • Replaceable Brushes • Hall Effect Encoder

D9

Overhung load 75 lbs.,
.75" from output boss

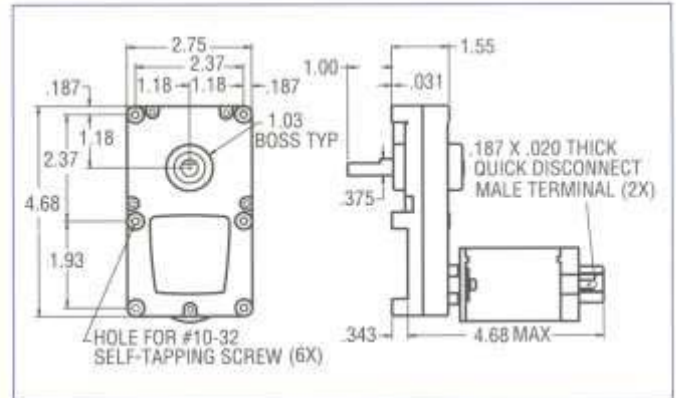

Input Motor	Gearmotor Characteristics	Nominal Gear Ratios					
		125	250	500	750	1500	3000
6000 RPM	F.L. Speed (RPM)	48	24	12	8	4	2
	F.L. Torque (in-lbs.)	17	35	79	105	200	200

Options • Available 12, 24 or 36 Volt • Replaceable Brushes • Hall Effect Encoder • Double Output Shaft

VW83

Overhung load 50 lbs.,
.44" from output boss

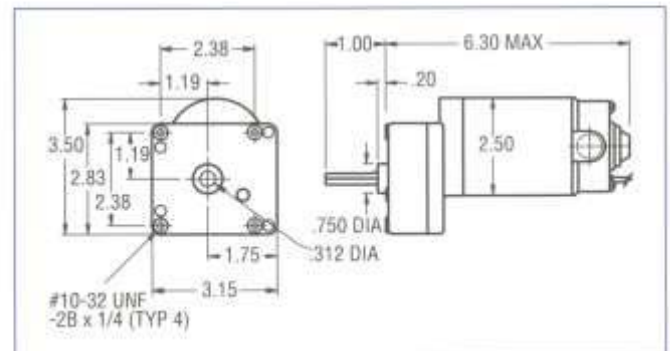

Input Motor	Gearmotor Characteristics	Standard Gear Ratios									
		18	31	50	63	98	161	314	482	975	1780
3000 RPM	F.L. Speed (RPM)	166	96	60	47	31	19	10	7	3.4	2
	F.L. Torque (in-lbs.)	11	18	28	36	50	50	50	50	50	50

Options • Available 12 - 180 Volt • Replaceable Brushes • Internal Brushes • Integral Speed Control

VW70

Overhung load 75 lbs.,
.60" from output boss

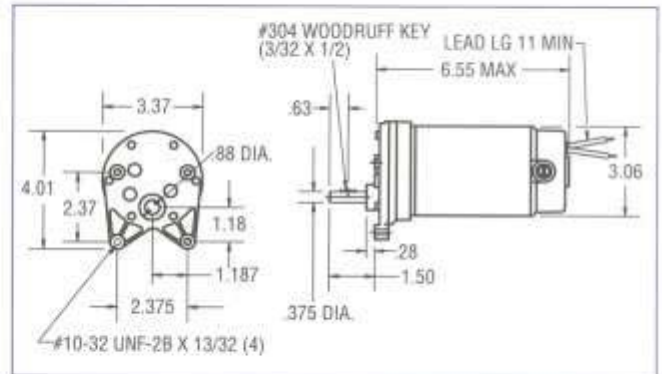

Input Motor	Gearmotor Characteristics	Standard Gear Ratios				
		9.3	14	19	29	54
3300 RPM	F.L. Speed (RPM)	356	244	178	113	62
	F.L. Torque (in-lbs.)	11	16	22	35	50
1650 RPM	F.L. Speed (RPM)	178	122	89	58	34
	F.L. Torque (in-lbs.)	19	27	38	50	50

Options

- Available 12 - 90 Volt
- Electro-Magnetic Brake
- Replaceable Brushes
- Integral Speed Control
- Internal Brushes

VW80

Overhung load 75 lbs.,
.60" from output boss

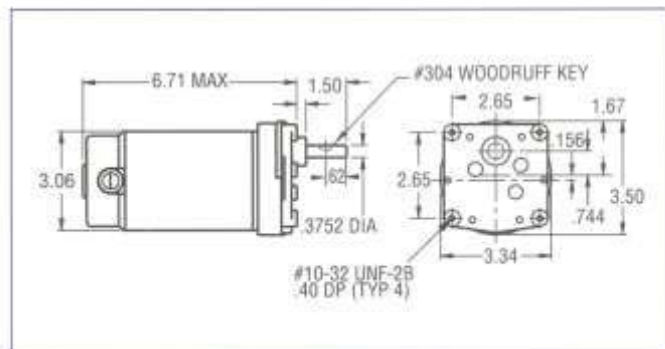

Input Motor	Gearmotor Characteristics	Standard Gear Ratios				
		9.3	14	19	29	54
3300 RPM	F.L. Speed (RPM)	356	244	178	113	62
	F.L. Torque (in-lbs.)	11	16	22	35	50
1650 RPM	F.L. Speed (RPM)	178	122	89	58	34
	F.L. Torque (in-lbs.)	19	27	38	50	50

Options

- Available 12 - 90 Volt
- Electro-Magnetic Brake
- Replaceable Brushes
- Integral Speed Control
- Internal Brushes

Speed Control

VWE-PH-M015
Motor Speed Control



- Input Voltage - 120 vac/60 Hz
- Max. Input Rating - 3 amps, 1/6 hp
- Output - 90 vdc full wave rectified
- Min/Max Speed Adjustment
- Max Torque Adjustment

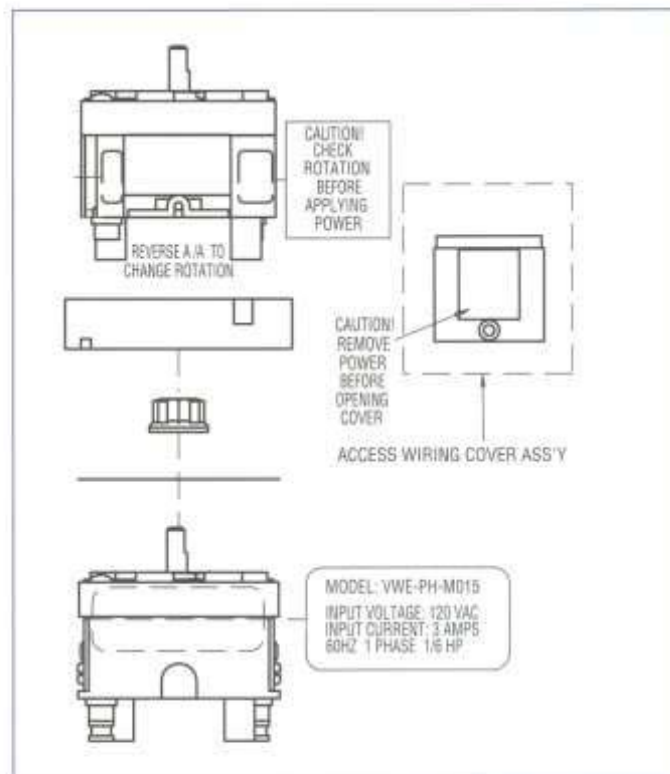



US76

Overhung load 100 lbs.,
1.0" from output boss;
Intermittent Duty

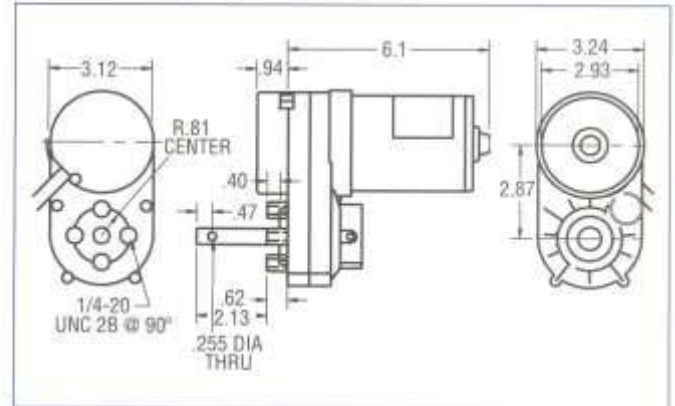

Input Motor	Gearmotor Characteristic	Standard Gear Ratios					
		4	7	11	16	19	28
3200 RPM	F.L. Speed (RPM)	800	434	280	196	168	114
	F.L. Torque (in-lbs.)	6	11	16	24	28	39
1600 RPM	F.L. Speed (RPM)	400	217	140	98	84	57
	F.L. Torque (in-lbs.)	12	22	33	48	57	78

Options

- Available 12 - 48 Volt
- Internal Brushes
- Limit Switches
- Potentiometer
- Double Output Shaft
- Reed Switch



VW76

Overhung load 100 lbs.,
1.0" from output boss;
Intermittent Duty

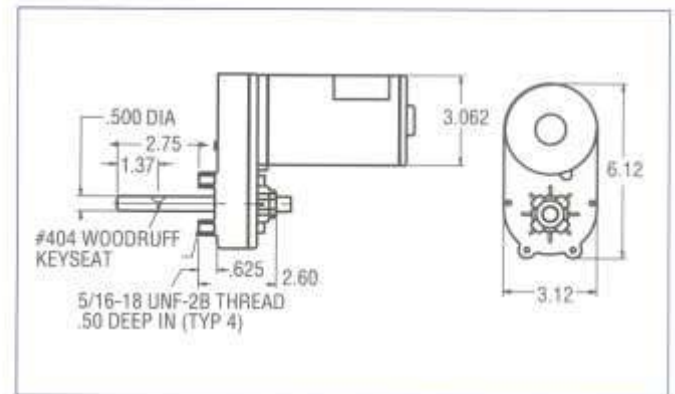

Input Motor	Gearmotor Characteristic	Standard Gear Ratios									
		4	7	16	19	28	42	52	61	72	
3200 RPM	F.L. Speed (RPM)	800	434	196	168	114	75	60	50	44	
	F.L. Torque (in-lbs.)	6	11	24	28	39	50	70	85	85	
1600 RPM	F.L. Speed (RPM)	400	217	98	84	57	38	30	25	22	
	F.L. Torque (in-lbs.)	12	22	48	57	78	100	140	150	150	

Options

- Available 12 - 90 Volt
- Replaceable Brushes
- Internal Brushes
- Electro-Magnetic Brake
- Limit Switches
- Reed Switch
- Opto Switch
- Potentiometer
- Double Output Shaft
- Integral Speed Control

VW31

Overhung load 50 lbs.,
.44" from output boss

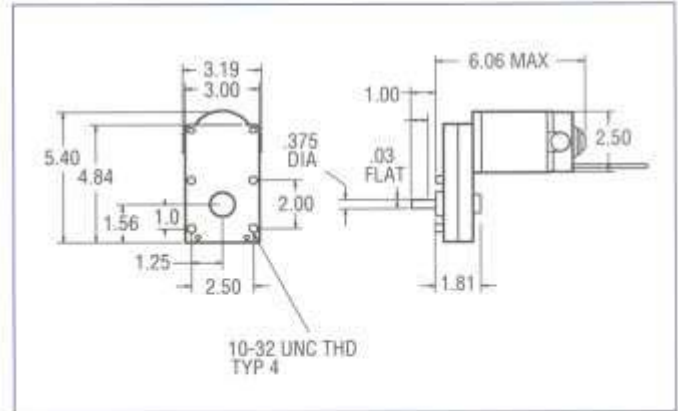

Input Motor	Gearmotor Characteristics	Standard Gear Ratios					
		16	34	65	97	163	311
3000 RPM	F.L. Speed (RPM)	188	88	46	31	18	10
	F.L. Torque (in-lbs.)	9	19	35	52	87	150

Options

- Available 12 - 180 Volt
- Replaceable Brushes
- Internal Brushes
- Double Output Shaft
- Integral Speed Control

VW53

Overhung load 7 lbs.,
.44" from output boss

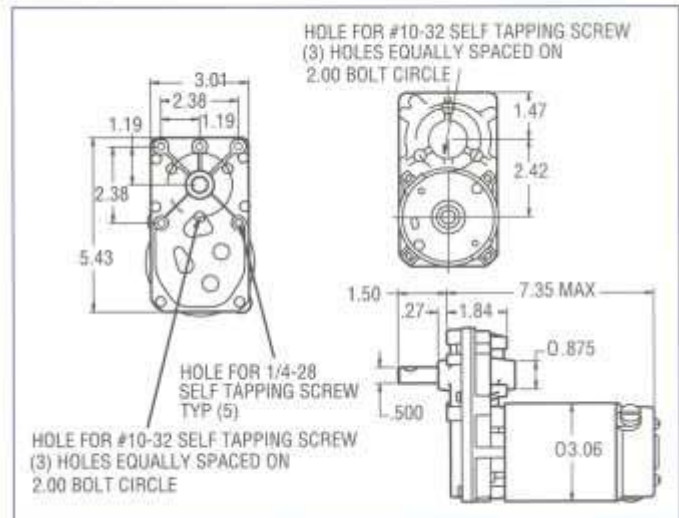

Input Motor	Gearmotor Characteristics	Standard Gear Ratios									
		18	25	30	50	61	86	112	125	161	203
1725 RPM	F.L. Speed (RPM)	94	70	58	35	28	20	15	14	11	8
	F.L. Torque (in-lbs.)	20	27	33	54	66	84	99	99	115	130

Options

- Available 12-180 Volt
- Replaceable Brushes
- Double Output Shaft

VW88

Overhung load 150 lbs.,
.94" from output boss

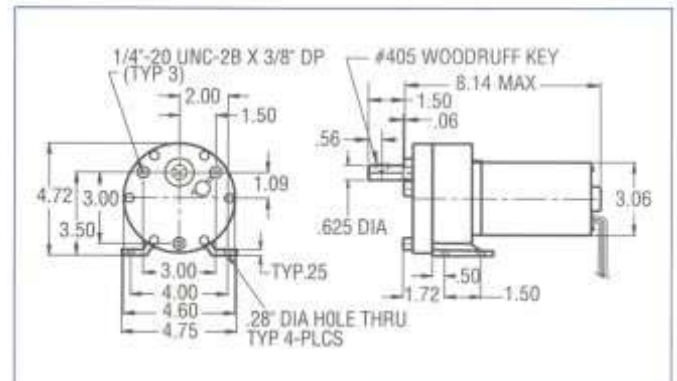

Input Motor	Gearmotor Characteristics	Standard Gear Ratios								
		7.2	14.3	27	52	78	128	250	739	1446
3300 RPM	F.L. Speed (RPM)	455	231	123	64	42	26	14	4.6	2.4
	F.L. Torque (in-lbs.)	11	20	36	70	102	150	150	150	150
1650 RPM	F.L. Speed (RPM)	228	115	62	32	22	13	7	2.5	1.3
	F.L. Torque (in-lbs.)	18	34	61	119	150	150	150	150	150

Options

- Available 12 - 90 Volt
- Electro-Magnetic Brake
- Replaceable Brushes
- Integral Speed Control
- Internal Brushes

VW89

Overhung load 150 lbs.,
.94" from output boss

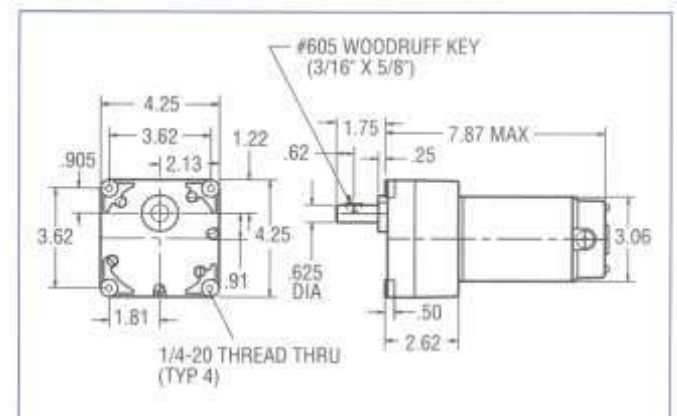

Input Motor	Gearmotor Characteristics	Standard Gear Ratios				
		10	14	18	27	53
3300 RPM	F.L. Speed (RPM)	330	236	183	122	62
	F.L. Torque (in-lbs.)	12	17	21	32	63
1650 RPM	F.L. Speed (RPM)	165	118	92	61	31
	F.L. Torque (in-lbs.)	20	28	36	54	106

Options

- Available 12 - 90 Volt
- Electro-Magnetic Brake
- Replaceable Brushes
- Integral Speed Control
- Internal Brushes

VW51

Overhung load 200 lbs.,
.75" from output boss

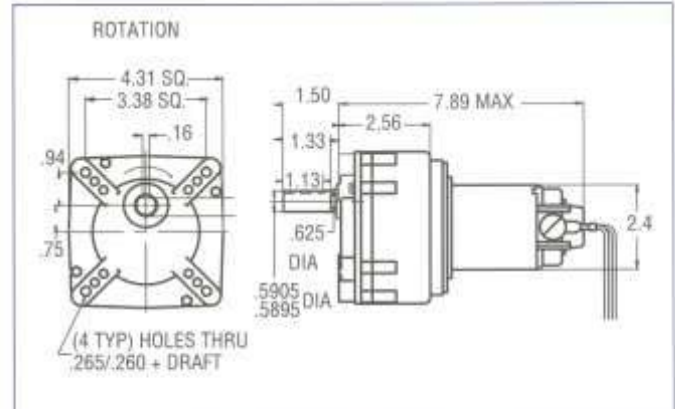

Input Motor	Gearmotor Characteristics	Standard Gear Ratios											
		13	19	25	32	46	69	93	132	162	200	245	327
2000 RPM	F.L. Speed (RPM)	159	107	79	62	43	29	21	15	12	10	8	6
	F.L. Torque (in-lbs.)	24	35	48	61	79	117	159	202	248	306	375	500

Options • Available 12 - 180 Volt • Replaceable Brushes

VW130

Overhung load 400 lbs.,
.75" from output boss

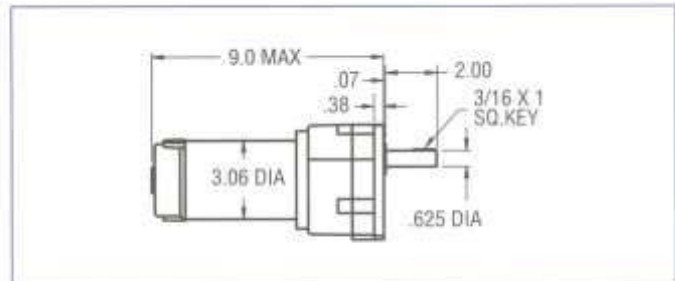

Refer to page 15 for mounting instructions.

Input Motor	Gearmotor Characteristics	Standard Gear Ratios											
		10	15	21	26	37	55	75	107	131	162	198	264
3200 RPM	F.L. Speed (RPM)	314	212	156	122	86	58	42	30	24	20	16	12
	F.L. Torque (in-lbs.)	18	27	37	47	63	94	127	170	210	259	324	425
1600 RPM	F.L. Speed (RPM)	157	106	78	61	43	29	21	15	12	10	8	6
	F.L. Torque (in-lbs.)	30	45	61	78	105	156	212	283	350	432	500	500

Options • Available 12 - 90 Volt • Replaceable Brushes • Internal Brushes
• Electro-Magnetic Brake • Integral Speed Control

VW84

Overhung load 250 lbs.,
.87" from output boss

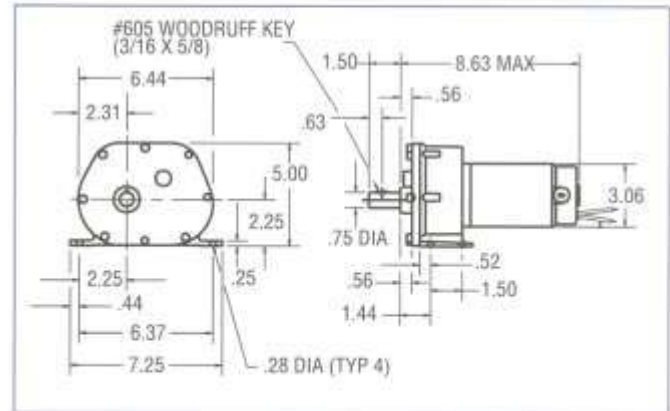

Input Motor	Gearmotor Characteristics	Standard Gear Ratios				
		32	56	81	133	267
3300 RPM	F.L. Speed (RPM)	103	58	40	24	12
	F.L. Torque (in-lbs.)	39	68	98	162	325
1650 RPM	F.L. Speed (RPM)	51	29	20	12	6
	F.L. Torque (in-lbs.)	65	114	167	276	553

Options

- Available 12 - 90 Volt
- Electro-Magnetic Brake
- Replaceable Brushes
- Integral Speed Control
- Internal Brushes

VW47

Overhung load 550 lbs.,
.75" from output boss

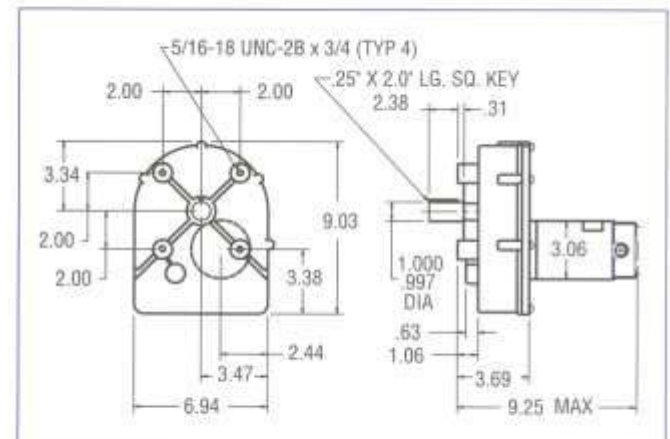

Input Motor	Gearmotor Characteristics	Standard Gear Ratios			
		249	540	827	1586
3300 RPM	F.L. Speed (RPM)	12	6	4	2
	F.L. Torque (in-lbs.)	750	1400	950	1900
1650 RPM	F.L. Speed (RPM)	6	3	2	1
	F.L. Torque (in-lbs.)	1033	2084	1650	3000

Options

- Available 12 - 90 Volt
- Electro-Magnetic Brake
- Replaceable Brushes
- Integral Speed Control
- Internal Brushes

VW400

Overhung load 400 lbs.,
.75" from output boss

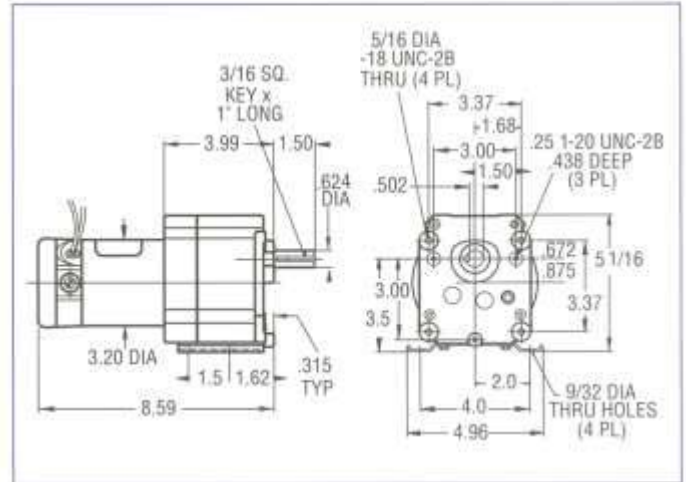

Input Motor	Gearmotor Characteristics	Standard Gear Ratios											
		5	11	13	19	30	43	65	80	130	190	265	400
1725 RPM	F.L. Speed (RPM)	345	157	135	90	60	40	27	21	13.5	9	7	6
	F.L. Torque (in-lbs.)	28	58	68	100	150	215	325	370	375	425	425	425

Options

- Available 12 - 180 Volt
- Replaceable Brushes
- Electro-Magnetic Brake

VW375

Overhung load 200 lbs.,
.75" from output boss

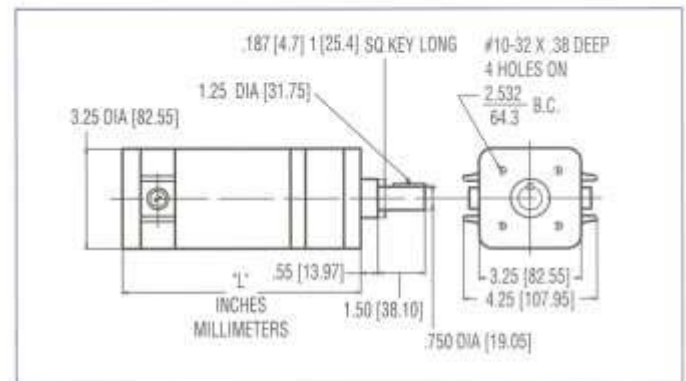

Input Motor	Gearmotor Characteristics	Standard Gear Ratios				
		6	36	216	1296	7776
1725 RPM	F.L. Speed (RPM)	288	48	8	1.3	0.02
	F.L. Torque (in-lbs.)	35	200	375	375	375

Options

- Available 12 - 180 Volt
- Replaceable Brushes
- Electro-Magnetic Brake



VW62

Overhung load 300 lbs.,
.87" from output boss

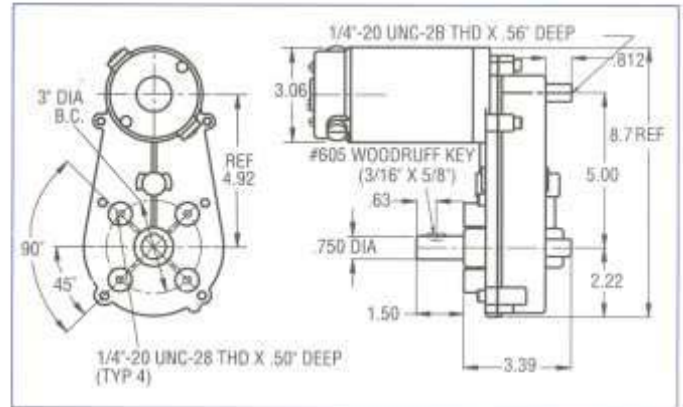

Input Motor	Gearmotor Characteristics	Standard Gear Ratios				
		32	56	81	133	267
3300 RPM	F.L. Speed (RPM)	103	58	40	24	12
	F.L. Torque (in-lbs.)	39	68	98	162	325
1650 RPM	F.L. Speed (RPM)	51	29	20	12	6
	F.L. Torque (in-lbs.)	65	114	167	276	553

Options

- Available 12 - 90 Volt
- Replaceable Brushes
- Internal Brushes
- Double Output Shaft
- Electro-Magnetic Brake
- Integral Speed Control



VW62S

Overhung load 300 lbs.,
.87" from output boss

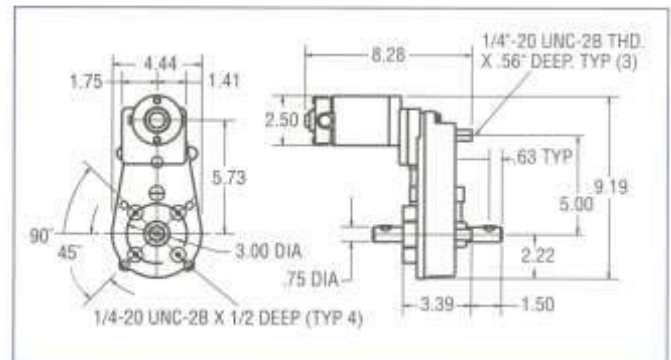

Input Motor	Gearmotor Characteristics	Standard Gear Ratios		
		1458	2261	4539
3000 RPM	F.L. Speed (RPM)	2	1.2	0.6
	F.L. Torque (in-lbs.)	600	600	600

Options

- Available 12 - 180 Volt
- Replaceable Brushes
- Internal Brushes
- Integral Speed Control