

Motor Wiring and Performance

(see following page for wiring diagrams)

- Geartrains simply take input speed and torque and multiply or divide them depending on ratio. Some torque is lost due to friction, but the basic output performance mimics the input performance, just scaled up or down for ratio. Therefore, the motor performance characteristics you see on this page will be the same characteristics that you would see from a gearmotor.
- Shaded pole motors run on AC voltage and only rotate in one direction. Standard models have only two lead wires and can be turned on and off by putting voltage across the two wires. Performance characteristics are similar to PSC. Wiring (1). Performance (1).
- PSC (permanent split capacitor motors) run on AC voltage and are reversible. The capacitor must be in the circuit at all times for the unit to run properly. Standard models have three or five lead wires and should be hooked up as shown in Wiring (2a) or (2b) Performance (1).
- Split phase motors run on AC voltage and are reversible. Split phase motors have one winding that is always on line and one that is only used for starting. A centrifugal switch releases when the motor comes up to speed, or a relay releases when the motor's inrush current subsides and removes the start winding from the circuit. If the start winding remains on line for an extended period, the motor will overheat. Wiring (3a) and (3b). Performance (2).
- CSIR (capacitor start-induction run) motors run on AC voltage and are reversible. They are constructed like split phase motors, but they have a capacitor connected between the run winding and the start winding for additional starting and pull-up torque. Wiring (4). Performance (2).
- Series wound motors run on either AC or DC voltage and are reversible. They are brush commutated and have fairly short brush life (less than 500 hours in some cases). Standard models have four wires lead and are wired as shown in Wiring (5). Performance (3).
- PMDC (permanent magnet DC) motors run on DC or rectified AC voltage and are reversible. The more closely the input voltage resembles pure DC, the more efficiently the motor runs (less heat rise, longer brush life). These motors have two lead wires and the direction of rotation is determined by the polarity of the input voltage. Wiring (6). Performance (4).

Shaded Pole & PSC Performance 1

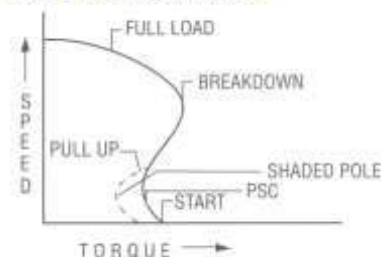

Split Phase & CSIR Performance 2

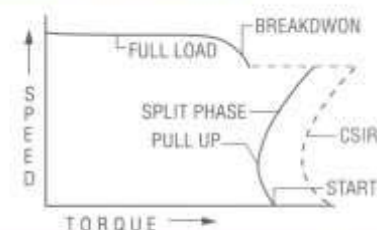

Series Performance 3

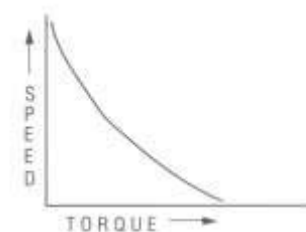

PMDC Performance 4

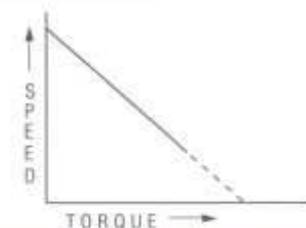

Motor Wiring and Performance (cont.)

Shaded Pole Wiring 1

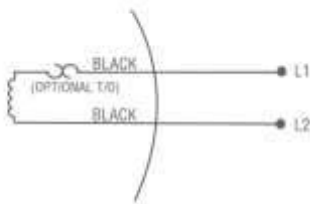

PSC (3 wire) Wiring 2a

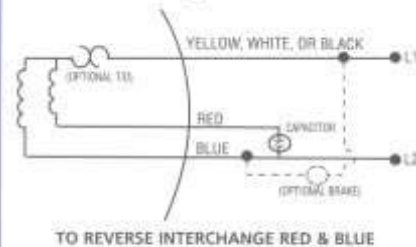

PSC (5 wire) Wiring 2b

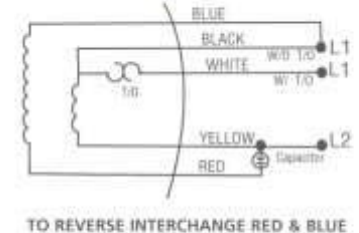

Split Phase (relay) Wiring 3a

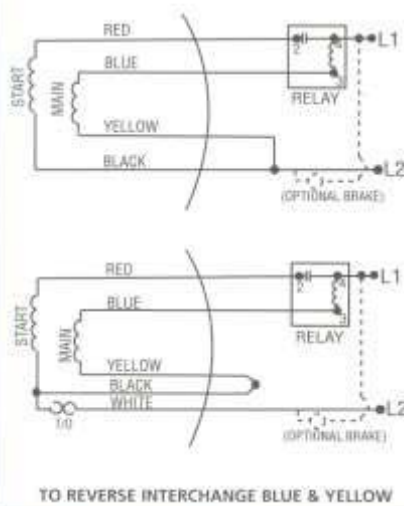

Split Phase (centrifugal switch) Wiring 3b

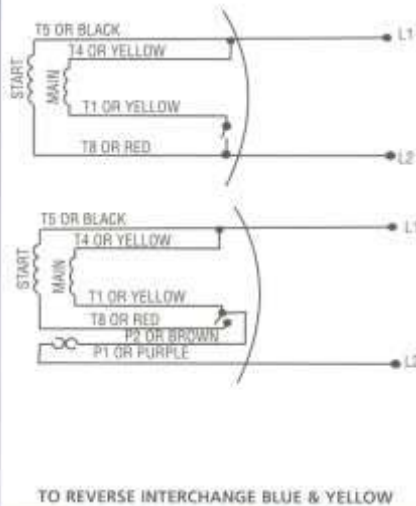

CSIR Wiring 4

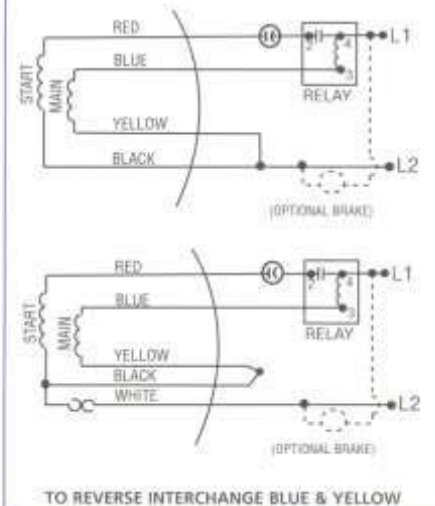

Series Wiring 5

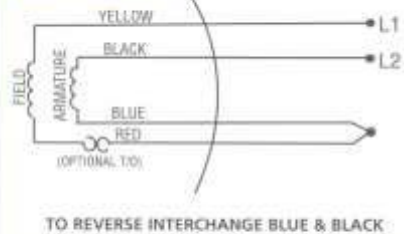

PMDC Wiring 6

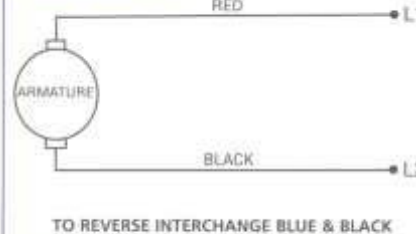

Torque Ratings vs. Duty Cycle

All gearmotors have duty cycle specified on individual pages. For those that are rated continuous, the motor, bearings, gears and shafts are designed to run continuously at the listed torque value without overheating. Lower torque amounts can extend life or specifying a particular life can help you. Torque levels higher than specified are sometimes possible on an intermittent basis, at times up to 1.5 times rated load. If, however, these loads will be frequent, premature failure may occur. Again, VonWeise Gearmotors can help you specify your needs.

For the right angle models rated as intermittent, the motor and power train can operate for sustained periods (up to several hours) at rated torque values, but when run continuously the motor can deteriorate rapidly. Used typically in cycling operations, where the duty cycle precludes mechanical overheating, these units can provide many years of reliable service.

For intermittent applications, many times a smaller, more cost effective motor or gearbox can be used. Be sure to specify duty cycle completely on application data sheets so that the optimum gearmotor can be selected.

Torque Overhung Load

All gearmotors have torque and overhung load specified on individual pages.

Torque is the tendency of your load to twist the output shaft of a gearmotor. Torque is measured as a force x a distance. For example, a (2) lbs. weight supported (12) inches away from the centerline of the output shaft of a gearmotor would require 2 lbs. X 12 in = 24 lb-ins of torque to move.

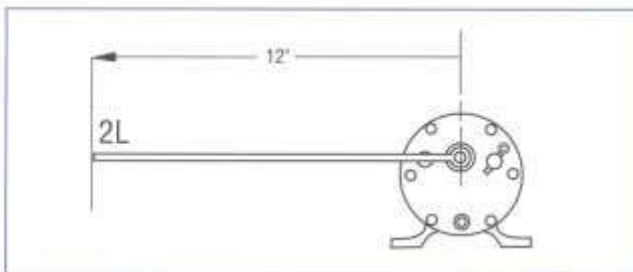

Knowing your exact torque requirements helps you optimize your gearmotor selection. You can get just the gearmotor you need, or if you want some safety margin, you'll know how much safety margin you've got. Torque can be measured using a torque wrench or using a wheel of a known diameter and force scale (similar to a postage or fish scale). Torque can also be calculated based on load and its vectoral distance from the gearmotor output shaft.

Your torque load is made up of a force at a distance and that force constitutes an overhung load. If the gearmotor/shaft couples to a shaft that is supported at each end, then you have isolated the overhung load from the gearmotor. In this case, be sure that the coupling arrangement allows for proper alignment between the gearmotor shaft and the supported shaft. If it doesn't, it can preload the bearings in the gearmotor and cause poor performance and premature failure.

If the gearmotor output shaft transmits its torque through a chain, pulley, gear train or rack and pinion, these devices will create an overhung load on the shaft. This load can be figured by the equation below:

$$\text{Overhung Load} = \frac{\text{Torque} \times K}{\text{Radius (of pulley, sprocket or pinion)}}$$

Or

$$\text{Overhung Load} = \frac{\text{Torque} \times 2 \times K}{\text{Diameter (of pulley, sprocket or pinion)}}$$

K is a load factor for the type of transmission you use. For chain and sprocket, K = 1.0; for gear and pinion or rack and pinion, K = 1.25; for belt and pulley, K = 1.5. Be sure that your pulley, sprocket or pinion diameter is large enough to stay within the published overhung load capacities.

How to use the Selection Guide of Stocked Gearmotors

Two key requirements in selecting a gearmotor are Speed (RPM) and Torque (in.lb.). These two specifications quickly determine the available models to consider. From this group, the best choice can be made by reviewing mounting configurations, shaft dimensions, voltage, etc.

Example:

A gearmotor is required to rotate a large display case at 6 RPM. The amount of torque needed – measured by a torque wrench – is 200 in.lb.

Step 1: Go to the AC section of the Selection Guide, since adjustable speed is not needed.

Step 2: Read down the RPM column to the grouping of 6 RPM models.

Step 3: In the adjacent Torque column find all the 6 RPM models with at least 200 in.lb. torque.

Step 4: With this group of gearmotors, review their voltage, mounting configuration, shaft characteristics, etc. for the gearmotor that best suits the application.

AC Gearmotors

(continued)

F/L RPM	F/L Torque in. Lbs.	Input HP	Volts		Motor Type	Grainger SKU	Gearbox Reference and Page
			60Hz	50HZ			
1	50	1/400	115		Shaded Pole	22804	VW11 Pg. 8
1	100	1/100	115	115	Shaded Pole	4LL05	VW11 Pg. 8
1	100	1/100	115		Shaded Pole	21001	VW707*
1	3000	1/15	115/230	115/230	P.S.C.	1L570	VW47 Pg. 16
1.3	250	1/50	115/230	115/230	P.S.C.	1L554	VW33 Pg. 20
2	25	1/400	115		Shaded Pole	22805	VW11 Pg. 8
2	113	1/10	115		Shaded Pole	1L490*	VW08 Pg. 12
2	113	1/20	115		Shaded Pole	3M125	VW08 Pg. 12
2	1900	1/12	115/230	115/230	P.S.C.	1L571	VW47 Pg. 16
3	200	1/20	115/230	115/230	P.S.C.	1L555	VW33 Pg. 20
3.5	50	1/250	115/230	115/230	P.S.C.	1L548	VW14 Pg. 8
4	130	1/90	115		Shaded Pole	62906	VW707*
5.6	200	1/14	115/230	115/230	P.S.C.	1L556	VW33 Pg. 20
6	22.5	1/330	115		Shaded Pole	22806	VW11 Pg. 8
6	40	1/100	115	115	Shaded Pole	4LL06	VW11 Pg. 8
6	113	1/10	115		Shaded Pole	1L489*	VW08 Pg. 12
6	113	1/20	115		Shaded Pole	3M126	VW08 Pg. 12
6	113	1/10	115		Shaded Pole	3M135	VW08 Pg. 12
6	250	2/85	115		Shaded Pole	62907	VW707*
6	500	1/15	115/230	115/230	P.S.C.	2H417	VW102 Pg. 14
6	500	1/15	115/230	115/230	P.S.C.	2H431	VW104 Pg. 14
6	600	1/12	115/230	115/230	P.S.C.	1L572	VW84 Pg. 16
6	600	1/4	115		Split Phase	5K933	VW20 Pg. 17
7	50	1/125	115/230	115/230	P.S.C.	1L549	VW14 Pg. 8
8	500	1/12	115/230	115/230	P.S.C.	2H433	VW104 Pg. 14
9	200	1/16	115/230	115/230	P.S.C.	1L557	VW33 Pg. 20
10	500	1/10	115/230	115/230	P.S.C.	2H419	VW102 Pg. 14
10	500	1/10	115/230	115/230	P.S.C.	2H435	VW104 Pg. 14
12	25.7	1/135	115		Shaded Pole	22807	VW11 Pg. 8
12	40	1/85	115	115	Shaded Pole	4LL07	VW11 Pg. 8
12	113	1/10	115		Shaded Pole	1L488*	VW08 Pg. 12
12	113	1/20	115		Shaded Pole	3M127	VW08 Pg. 12
12	113	1/10	115		Shaded Pole	3M136	VW08 Pg. 12
12	400	1/14	115/230	115/230	P.S.C.	1L573	VW84 Pg. 16
12	500	1/9	115/230	115/230	P.S.C.	2H437	VW104 Pg. 14
12	600	1/4	115		Split Phase	5K934	VW20 Pg. 17
15	340	1/10	115/230	115/230	P.S.C.	2H421	VW102 Pg. 14
15	500	1/8	115/230	115/230	P.S.C.	2H439	VW114 Pg. 14
18	550	1/4	115		Split Phase	5K935	VW20 Pg. 17
19	250	1/12	115/230	115/230	P.S.C.	1L574	VW84 Pg. 16
20	15.2	1/120	115		Shaded Pole	22808	VW11 Pg. 8
20	500	1/6	115/230	115/230	P.S.C.	2H441	VW114 Pg. 14

* Not in catalog

F/L RPM	F/L Torque in. Lbs.	Input HP	Volts		Motor Type	Grainger SKU	Gearbox Reference and Page
			60Hz	50HZ			
21	170	1/12	115/230	115/230	P.S.C.	1L558	VW33 Pg. 20
25	45	1/85	115		Shaded Pole	62908	VW707*
28	175	1/13	115/230	115/230	P.S.C.	1L575	VW84 Pg. 16
29	150	1/13	115/230	115/230	P.S.C.	1L586	VW89 Pg. 13
29	185	1/10	115/230	115/230	P.S.C.	2H423	VW102 Pg. 14
30	11.6	1/120	115		Shaded Pole	22809	VW11 Pg. 8
30	42	1/20	115		Shaded Pole	3M128	VW08 Pg. 12
30	113	1/10	115		Shaded Pole	3M137	VW08 Pg. 12
30	113	1/10	115		Shaded Pole	3M158*	VW08 Pg. 12
30	400	1/4	115		Split Phase	5K939	VW20 Pg. 17
30	800	1/2	115		Split Phase	22794	VW40 Pg. 17
31	360	1/5	115/230	110/220	P.S.C.	2H444	VW114 Pg. 14
35	50	1/25	115/230	115/230	P.S.C.	1L550	VW14 Pg. 8
39	89	1/12	115/230	115/230	P.S.C.	1L559	VW33 Pg. 20
40	330	1/4	115		Split Phase	5K941	VW20 Pg. 17
42	125	1/10	115/230	115/230	P.S.C.	2H425	VW102 Pg. 14
43	265	1/5	115/230	110/220	P.S.C.	2H446	VW114 Pg. 14
48	100	1/12	115/230	115/230	P.S.C.	1L576	VW84 Pg. 16
50	25	1/45	115		Shaded Pole	62909	VW707*
57	85	1/13	115/230	115/230	P.S.C.	1L587	VW89 Pg. 13
60	4.7	1/120	115		Shaded Pole	22810	VW11 Pg. 8
60	59	1/10	115		Shaded Pole	1L487*	VW08 Pg. 12
60	59	1/10	115		Shaded Pole	3M138	VW08 Pg. 12
60	93	1/10	115/230	115/230	P.S.C.	2H427	VW102 Pg. 14
60	200	1/4	115		Split Phase	5K940	VW20 Pg. 17
60	400	1/2	115		Split Phase	22795	VW40 Pg. 17
63	180	1/5	115/230	110/220	P.S.C.	2H449	VW114 Pg. 14
67	30	1/25	115/230	115/230	P.S.C.	1L551	VW14 Pg. 8
86	55	1/12	115/230	115/230	P.S.C.	1L588	VW89 Pg. 13
90	150	1/4	115		Split Phase	6K993	VW20 Pg. 17
90	287	1/2	115		Split Phase	22796	VW40 Pg. 17
91	130	1/5	115/230	110/220	P.S.C.	2H451	VW114 Pg. 14
107	20	1/20	115/230	110/220	P.S.C.	1L552	VW14 Pg. 8
120	2.7	1/120	115		Shaded Pole	22811	VW11 Pg. 8
120	100	1/4	115		Split Phase	5K942	VW20 Pg. 17
155	30	1/12	115/230	115/230	P.S.C.	1L589	VW89 Pg. 13
155	36	1/10	115/230	115/230	P.S.C.	2H429	VW102 Pg. 14
156	77	1/5	115/230	110/220	P.S.C.	2H453	VW114 Pg. 14
185	12	1/20	115/230	115/230	P.S.C.	1L553	VW14 Pg. 8
200	1.18	1/120	115		Shaded Pole	22812	VW11 Pg. 8
200	4	1/45	115	115	Shaded Pole	4LL08	VW11 Pg. 8
360	3	1/45	115	115	Shaded Pole	4LL09	VW11 Pg. 8

DC Gearmotors

F/L RPM	F/L Torque in Lbs.	Input HP	Volts DC	Grainger SKU	Gearbox Reference and Page
0.45	50	1/1200	12	4Z832	D10HA Pg. 23
1.5	25	1/1000	12	4Z833	D10HA Pg. 23
3.4	30	1/400	12	4Z834	D10HA Pg. 23
4.5	38	1/200	12	4Z835	D10HA Pg. 23
6	50	1/30	12	1L480	VW83 Pg. 29
6	500	1/15	12	1L474	VW84 Pg. 35
9	35	1/120	12	4Z836	D10HA Pg. 23
9	50	1/30	12	1L479	VW83 Pg. 29
12	40	1/90	12	4Z837	D10H Pg. 23
12	250	1/15	12	1L473	VW84 Pg. 35
17	16	1/160	12	4Z838	D10H Pg. 22
20	150	1/15	12	1L472	VW84 Pg. 35
21	50	1/30	12	1L478	VW83 Pg. 29
25	15	1/160	12	4Z839	D10H Pg. 22
32	40	1/30	12	1L477	VW83 Pg. 29
40	75	1/8	12	1L471	VW84 Pg. 35
50	10	1/90	12	4Z840	D10H Pg. 22
50	26	1/30	12	1L476	VW83 Pg. 29
60	75	1/8	12	1L470	VW84 Pg. 35
90	50	1/8	12	1L469	VW84 Pg. 35
102	13	1/30	12	1L475	VW83 Pg. 29
3.2	250	1/15	90	4Z723	VW33 Pg. 40
6	177	1/12	90	4Z724	VW33 Pg. 40
6	500	1/15	90	2H455	VW132 Pg. 34
6	500	1/15	90	2H467	VW134 Pg. 34
6.5	500	1/15	90	4Z530	VW84 Pg. 35
7	50	1/100	90	4Z534	VW83 Pg. 29
10	228	1/12	90	4Z725	VW33 Pg. 40
11	50	1/75	90	4Z535	VW83 Pg. 29
12	350	1/12	90	2H457	VW132 Pg. 34
12	350	1/12	90	2H469	VW134 Pg. 34
13	250	1/15	90	4Z531	VW84 Pg. 35
21	50	1/30	90	4Z536	VW83 Pg. 29
21	150	1/15	90	4Z532	VW84 Pg. 35
23.5	102	1/12	90	4Z726	VW33 Pg. 40
29	156	1/12	90	2H459	VW132 Pg. 34
29	156	1/12	90	2H471	VW134 Pg. 34
32	43	1/30	90	4Z537	VW83 Pg. 29
42	75	1/15	90	4Z533	VW84 Pg. 35
43	105	1/12	90	2H461	VW132 Pg. 34
43	105	1/12	90	2H473	VW134 Pg. 34
45	56	1/12	90	4Z727	VW33 Pg. 40
50	26	1/30	90	4Z538	VW83 Pg. 29
61	78	1/12	90	2H463	VW132 Pg. 34
61	78	1/12	90	2H475	VW134 Pg. 34
89	34	1/15	90	4Z728	VW33 Pg. 40
102	13	1/30	90	4Z539	VW83 Pg. 29
157	30	1/12	90	2H465	VW132 Pg. 34
157	30	1/12	90	2H477	VW134 Pg. 34

* Not in catalog

Universal AC/DC Series

F/L RPM	F/L Torque in Lbs.	Input HP	Volts			Motor Type	Grainger SKU	Gearbox Reference and Page
			60Hz	50HZ	50HZ			
2.8	250	1/15	115	115	115	Left Hand	2Z797	VW03 Pg. 41
4.0	250	1/15	115	115	115	Right Hand	1L486	VW03 Pg. 41
6.7	162	1/15	115	115	115	Left Hand	2Z798	VW03 Pg. 41
6.7	162	1/15	115	115	115	Right Hand	1L485	VW03 Pg. 41
12.8	110	1/15	115	115	115	Left Hand	2Z799	VW03 Pg. 41
12.8	110	1/15	115	115	115	Right Hand	1L484	VW03 Pg. 41
21	100	1/15	115	115	115	Left Hand	2Z800	VW03 Pg. 41
21	100	1/15	115	115	115	Double	2Z801	VW03 Pg. 41
21	100	1/15	115	115	115	Right Hand	1L483	VW03 Pg. 41
50	45	1/15	115	115	115	Left Hand	2Z802	VW03 Pg. 41
50	45	1/15	115	115	115	Right Hand	1L482	VW03 Pg. 41
100	27	1/15	115	115	115	Left Hand	2Z803	VW03 Pg. 41
100	27	1/15	115	115	115	Right Hand	1L481	VW03 Pg. 41

NOTE: DC and AC/DC Gearmotors are listed with F/L RPM at maximum voltage shown. They are typically operated with a speed control allowing speed adjustment from 0 to the F/L RPM listed. Please refer to the index for motor controls. For Linear Actuators, see page 42.